

# IDEAL VT85SP

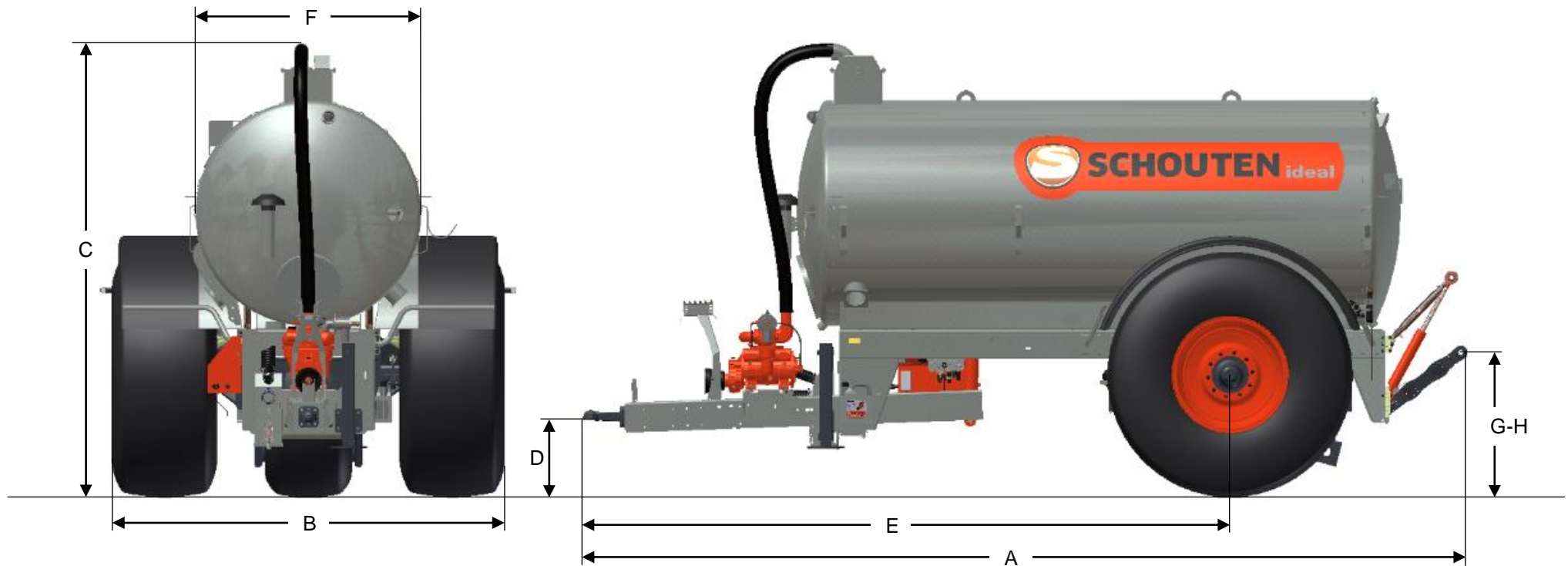

## DIMENSIONS

A	LENGTH	6612 MM	E	DISTANCE HITCH - AXLE	4818 MM
B	WIDTH	2870 MM	F	TANK DIAMETER	1700 MM
C	HEIGHT	3425 MM	G	LIFT HEIGHT MIN.	235 MM
D	HITCH HEIGHT	400-700 MM	H	LIFT HEIGHT MAX.	990 MM

# IDEAL VT85SP

## MACHINE INFORMATION

TYPE	VT85SP
WEIGHT	4.600 KG
TANK DIMENSIONS	Ø1700X4040 MM
TANK VOLUME	8.000 L
LEVEL INDICATOR	FLOAT POINTER
UNDERCARRIAGE	THREE-WHEEL
TYPE OF AXLE	BPW BRAKED □150MM
CARRYING CAPACITY AXLE	15.000 KG
TIRES	800/60R32 – 650/55R26.5

SUPPORT LEG	HYDR. DA
VACUUM PUMP	B&P MEC11000
CAPACITY VACUUM PUMP	11.137 L/MIN
VACUUM PUMP DRIVE	PTO 540/1000RPM
MOISTURE TRAP CAPACITY	15.500 L/MIN
LIFT POSSIBILITIES	GRASSLAND/BLACK SOIL
LIFT CAPACITY	3.500 KG
LIFT SYSTEM	4-POINT CAT III

## OPTIONS

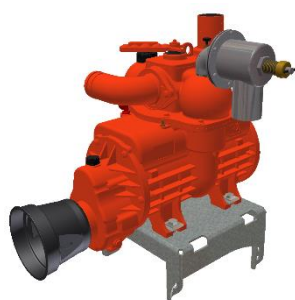

B&P MEC13500

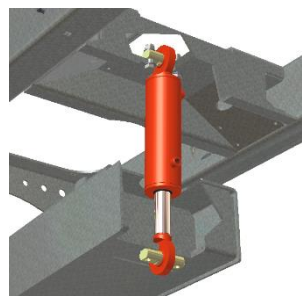

HYDR. DRAWBAR SUSPENSION

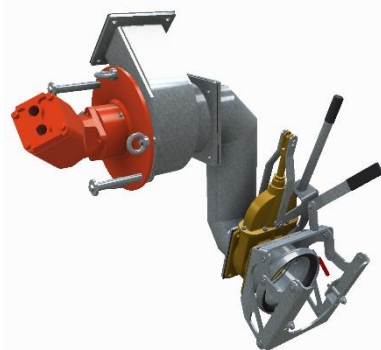

TURBO-FILLER 8-6



DOCKING FILLING ARM 8"



FILLING ARM 10" TURBO